

**ISUZU BERPENGALAMAN DENGAN
MESIN COMMON RAIL SEJAK 2011**

**ISUZU
GIGA
FVR**

**IRIT MAKSIMAL,
TENAGA DAN
MUATAN OPTIMAL**



**euro4
ready**

*Gambar pada brosur ini hanya ilustrasi, mungkin ada perbedaan dengan aktual kendaraan
**Mesin common rail pada Isuzu Giga sejak tahun 2011

REAL PARTNER. REAL JOURNEY.

SPESIFIKASI TEKNIS

SPESIFIKASI	FVR L D	FVR P	FVR Q	FVR S	FVR U	
SISTEM PENGGERAK RODA / DRIVETRAIN						
Sistem Penggerak Roda / Drive Train	4X2					
DIMENSI / DIMENSION						
Panjang / Overall Length [OAL]	mm	7,595	8,845	9,895	10,640	11,950
Lebar / Overall Width [OW]	mm	2,465				
Tinggi / Overall Height [OH]	mm	2,930				
Jarak Sumbu / Wheelbase [WB]	mm	4,300	5,060	5,560	6,160	6,600
Julur Depan / Front Overhang [FOH]	mm	1,250				
Julur Belakang / Rear Overhang [ROH]	mm	2,045	2,535	3,085	3,230	4,100
Jarak Terendah ke Tanah / Minimum Clearance [H#]	mm	260		265		
Dimensi Chassis	mm	870 x 275 x 7.5				
Jejak Depan / Front Tread [AW]	mm	2,060				
Jejak Belakang / Rear Tread [CW]	mm	1,850				
Cabin to End [CE]	mm	5,490	6,740	7,790	8,540	9,840
MESIN / ENGINE						
Model	6 HK1-TCN					
Tipe / Type	Direct Injection, OHC, 6 Cylinder, Heavy Duty Commonrail, VGS Turbo Intercooler					
Sistem Kontrol Emisi	EURO4 with EGR & DOC					
Diameter x Langkah / Bore x Stroke	mm	115 X 125				
Isi Silinder / Piston Displacement	cc	7,790				
Tenaga Maksimum / Maximum Power	PS/tpm	245 / 2,400				
Torsi Maksimum / Maximum Torque	Kgm/tpm	80.5 / 1,450 - 2,400				
TRANSMISI / TRANSMISSION						
Model	E59306A					
Perbandingan Gigi / Gear Ratio	1st	9.010				
	2nd	5.270				
	3rd	3.220				
	4th	2.040				
	5th	1.360				
	6th	1.000				
	Rev	8.630				
Perbandingan Gigi Terakhir / Final Gear Ratio		5.857	5.571			

SPESIFIKASI	FVR L D	FVR P	FVR Q	FVR S	FVR U	
BERAT / WEIGHT						
Berat Kosong Kendaraan / Curb Weight	kg	5,370	5,520	5,510	5,680	5,780
Berat Total Kendaraan / Gross Vehicle Weight [GVW]	kg	16,000				
Kapasitas Gardan Depan / Capacity Front Axle	kg	6,000				
Kapasitas Gardan Belakang / Capacity Rear Axle	kg	10,000				
REM / BRAKE						
Tipe / Type	Full Air Brake					
Rem Kaki / Service Brake	Full Air dengan Drum Brake					
Rem Tangan / Hand Brake	Mekanisme Tuas, dengan Air Valve					
Sistem Pengereman Gas Buang / Exhaust Brake	Ada					
RODA / TYRE						
Ukuran Ban	10.00-20-16PR					
Ukuran Velg	10STUD 20X7.50T					
SUSPENSI / SUSPENSION						
Depan / Front	Rigid Suspension dengan Multi Leaf Spring					
Belakang / Rear						
LAIN-LAIN / OTHERS						
Kapasitas Tangki / Fuel Tank Capacity	ltr	200				
Radius Putar Minimum / Minimum Turning Radius	m	7.3	8.3	9.1	9.7	10.4
Daya Tanjak Maksimum / Maximum Gradesability	%	45				
Kecepatan Maksimum / Maximum Speed	km/h	83		87		
Aki / Accu	V-Ah	2 x 12 V - 65 Ah				
Alternator	V-A	24 - 60				
Semi Float (Rubber) Damper Cabin Suspension	Ada					
Audio Head Unit	Ada					
USB Charging System	Ada					
APAR (Alat Pemadam Api Ringan)	Ada					
Kamera Mundur / Reverse Parking Camera	Ada					
Under Guard	Ada	-				
Seat Suspension	Ada	-				
Transmission PTO	Ada	-				
Garansi / Warranty	1 Tahun / 50,000 km					

*Untuk meningkatkan mutu dan menyesuaikan dengan perkembangan teknologi, spesifikasi dapat berubah sewaktu-waktu tanpa pemberitahuan. Ilustrasi merupakan contoh sebagian aplikasi di lapangan.

DIMENSI

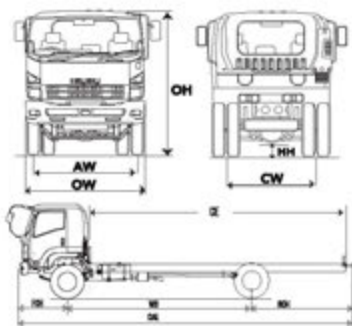

APLIKASI

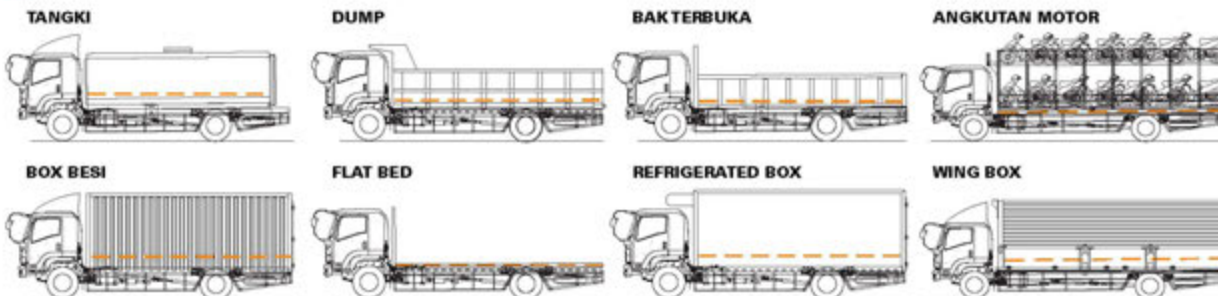

Agan Pemegang Merek & Distributor :
PT ISUZU ASTRA MOTOR INDONESIA



SCAN INI
UNTUK
INFORMASI
LEBIH LANJUT

