

**ISUZU BERPENGALAMAN DENGAN
MESIN COMMON RAIL SEJAK 2011**

**ISUZU
GIGA
FTR**



**IRIT MAKSIMAL,
MUATAN OPTIMAL**

**euro4
ready**

*Gambar pada brosur ini hanya ilustrasi, mungkin ada perbedaan dengan aktual kendaraan
**Mesin common rail pada Isuzu Giga sejak tahun 2011

REAL PARTNER. REAL JOURNEY.

SPESIFIKASI TEKNIS

SPESIFIKASI	FTR P	FTR S	FTR T
SISTEM PENGGERAK RODA / DRIVETRAIN			
Sistem Penggerak Roda / Drive Train		4X2	
DIMENSI / DIMENSION			
Panjang / Overall Length [OAL]	mm	8,550	10,785
Lebar / Overall Width [CW]	mm		2,400
Tinggi / Overall Height [OH]	mm		2,775
Jarak Sumbu / Wheelbase [WB]	mm	5,050	6,500
Julur Depan / Front Overhang [FOH]	mm		1,440
Julur Belakang / Rear Overhang [ROH]	mm	2,060	2,845
Jarak Terendah ke Tanah / Minimum Clearance [HH]	mm		276
Dimensi Chassis	mm	850 x 253 x 7.5	850 x 254 x 8
Jejak Depan / Front Tread [AW]	mm		1,990
Jejak Belakang / Rear Tread [CW]	mm		1,790
Cabin to End [CE]	mm	6,440	8,790
MESIN / ENGINE			
Model		4 HK1-TCS	
Tipe / Type		Direct Injection, OHC, 4 Cylinder, VGS Turbo Intercooler	
Sistem Kontrol Emisi		EURO4 with EGR & DOC	
Diameter x Langkah / Bore x Stroke	mm	115 X 125	
Isi Silinder / Piston Displacement	cc	5,193	
Tenaga Maksimum / Maximum Power	PS/rpm	210 / 2,600	
Torsi Maksimum / Maximum Torque	Kgm/rpm	72 / 1,600 - 2,600	
TRANSMISI / TRANSMISSION			
Model		MZW6P	
Perbandingan Gigi / Gear Ratio		1st	6.615
		2nd	4.095
		3rd	2.358
		4th	1.531
		5th	1.000
		6th	0.722
		Rev	6.615
Perbandingan Gigi Terakhir / Final Gear Ratio			6.500

SPESIFIKASI	FTR P	FTR S	FTR T
BERAT / WEIGHT			
Berat Kosong Kendaraan / Curb Weight	kg	4,340	4,500
Berat Total Kendaraan / Gross Vehicle Weight [GVW]	kg		14,000
Kapasitas Gardan Depan / Capacity Front Axle	kg		5,150
Kapasitas Gardan Belakang / Capacity Rear Axle	kg		8,850
REM / BRAKE			
Tipe / Type		AOH	
Rem Kaki / Service Brake		Air Over Hydraulic	
Rem Tangan / Hand Brake		Mekanisme Expanding di Transmisi Output	
Sistem Pengereman Gas Buang / Exhaust Brake		Ada	
RODA / TYRE			
Ukuran Ban		9.00-20-14PR [Miller]	
Ukuran Velg		8STUD 20X6.50T	
SUSPENSI / SUSPENSION			
Depan / Front		Rigid Suspension dengan Multi Leaf Spring	
Belakang / Rear			
LAIN-LAIN / OTHERS			
Kapasitas Tangki / Fuel Tank Capacity	litr	200	
Radius Putar Minimum / Minimum Turning Radius	m	8.7	10.3
Daya Tanjak Maksimum / Maximum Gradeability	%	35	
Kecepatan Maksimum / Maximum Speed	km/h	107	
Aki / Accu	V-Ah	2 x 12 V - 65 Ah	
Alternator	V-A	24 - 50	
Rubber Damper Cabin Suspension		Ada	
Audio Head Unit		Ada	
USB Charging System		Ada	
APAR (Alat Pemadam Api Ringan)		Ada	
Kamera Mundur / Reverse Parking Camera		Ada	
Garansi / Warranty		1 Tahun / 50,000 km	

* Untuk meningkatkan mutu dan penyesuaian dengan perkembangan teknologi, spesifikasi dapat berubah sewaktu-waktu tanpa pemberitahuan.

** Ilustrasi merupakan contoh sebagian aplikasi di lapangan.

DIMENSI

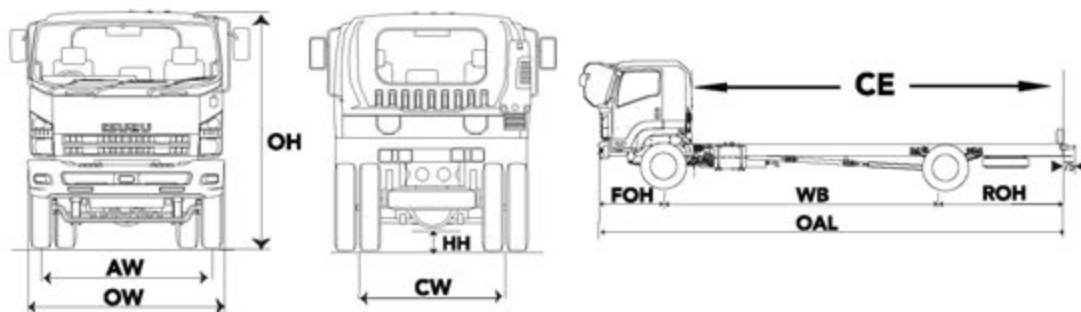

APLIKASI

WING BOX

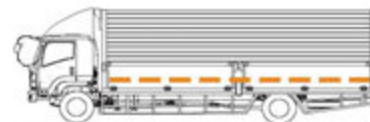

BOX ALUMINIUM



ANGKUTAN MOTOR

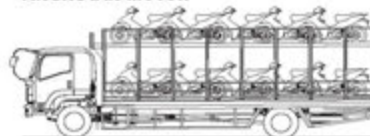

SCAN INI
UNTUK
INFORMASI
LEBIH LANJUT



Agan Pemegang Merek & Distributor :

PT ISUZU ASTRA MOTOR INDONESIA



ISUZU ID

ISUZU ID

www.isuzu-astra.com