

# ISUZU ELF NPS



**TANGGUH DI  
SEGALA MEDAN**

**TKDN**  
CERTIFIED

\*Gambar pada brosur ini hanya ilustrasi, mungkin ada perbedaan dengan aktual kendaraan  
\*\*Mesin common rail pada Isuzu Giga sejak tahun 2011

**REAL PARTNER. REAL JOURNEY.**

# SPESIFIKASI TEKNIS

SPESIFIKASI	NPS	
<b>SISTEM PENGGERAK RODA / DRIVE TRAIN</b>		
Sistem Penggerak Roda / Drive Train	4X4	
<b>DIMENSI / DIMENSION</b>		
Panjang / Overall Length [OAL]	mm	6,035
Lebar / Overall Width [OW]	mm	2,100
Tinggi / Overall Height [OH]	mm	2,465
Jarak Sumbu / Wheelbase [WB]	mm	3,395
Julur Depan / Front Overhang [FOH]	mm	1,090
Julur Belakang / Rear Overhang [ROH]	mm	1,550
Jarak Terendah ke Tanah / Min. Clearance [HH]	mm	215
Jejak Depan / Front Tread [AW]	mm	1,675
Jejak Belakang / Rear Tread [CW]	mm	1,650
Cabin to End [CE]	mm	4,192
<b>MESIN / ENGINE</b>		
Model	4HL1-TCS	
Tipe / Type	Direct Injection, Commonrail, SOHC, 4 Cylinder, VGS Turbo Intercooler	
Sistem Kontrol Emisi	EURO4 with EGR & DOC	
Diameter x Langkah / Bore x Stroke	mm	115 X 115
Isi Silinder / Piston Displacement	cc	4,778
Tenaga Maksimum / Max. Power	PS/rpm	150 / 2,600
Torsi Maksimum / Max. Torque	Kgm/rpm	41 / 1,400 - 2,600
<b>TRANSMISI / TRANSMISSION</b>		
Model	MYY5T	
Perbandingan Gigi / Gear Ratio	1st	5.315
	2nd	3.053
	3rd	1.655
	4th	1.000
	5th	0.721
	Rev	5.068
Perbandingan Gigi Terakhir / Final Gear Ratio	5.125	

\* Untuk meningkatkan mutu dan penyesuaian dengan perkembangan teknologi, spesifikasi dapat berubah sewaktu-waktu tanpa pemberitahuan.  
 \*\* Ilustrasi merupakan contoh sebagian aplikasi di lapangan.

SPESIFIKASI	NPS	
<b>BERAT / WEIGHT</b>		
Berat Kosong Kendaraan / Curb Weight	kg	2,730
Berat Total Kendaraan / Gross Vehicle Weight [GVW]	kg	6,000
Kapasitas Gardan Depan / Capacity Front Axle	kg	2,000
Kapasitas Gardan Belakang / Capacity Rear Axle	kg	4,000
<b>REM / BRAKE</b>		
Tipe/Type	Hydraulic	
Rem Kaki / Service Brake	Hydraulic saluran ganda dengan vacuum booster	
Rem Tangan / Hand Brake	Expanding pada transmisi belakang	
Sistem Pengereman Gas Buang / Exhaust Brake	Exhaust brake, tuas berada di stir	
<b>RODA / TYRE</b>		
Ukuran Ban	7.50-16-14PR	
Ukuran Velg	16 X 6.00	
<b>SUSPENSI / SUSPENSION</b>		
Depan / Front	Semi elliptical laminated leaf spring dengan shock absorber	
Belakang / Rear	berdaya ganda	
<b>LAIN-LAIN / OTHERS</b>		
Kapasitas Tangki / Fuel Tank Capacity	ltr	100
Radius Putar Minimum / Min. Turning Radius	m	6.9
Daya Tanjak Maksimum / Max. Gradeability	%	47
Kecepatan Maksimum / Max. Speed	km/h	112
Aki / Accu	V-Ah	2 X 12 V - 65 Ah
Alternator	V-A	24 - 60
Audio Head Unit	Ada	
USB Charging System	Ada	
APAR (Alat Pemadam Api Ringan)	Ada	
Fan Blower	Ada	
Garansi / Warranty	3 Tahun / 100,000 km	

## DIMENSI

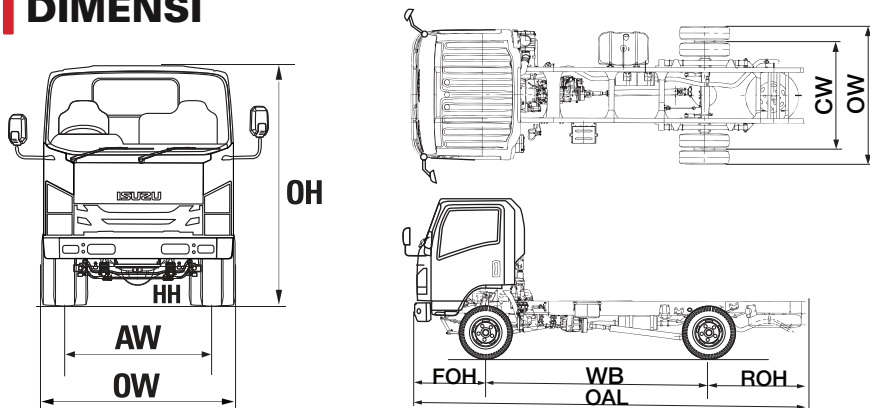

## APLIKASI

MINING & AGRICULTURE

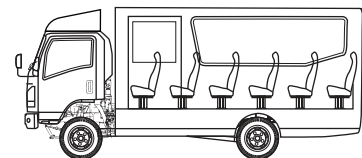

KENDARAAN KHUSUS

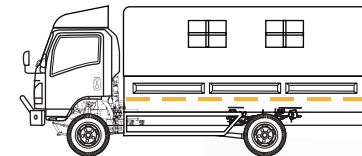

SCAN INI  
UNTUK  
INFORMASI  
LEBIH LANJUT



Agan Pemegang Merek & Distributor :

**PT ISUZU ASTRA MOTOR INDONESIA**



www.isuzu-astra.com