

**ISUZU BERPENGALAMAN DENGAN
MESIN COMMON RAIL SEJAK 2011**

NEW*

ISUZU
ELF
NMR



**IRIT MAKSIMAL,
TENAGA OPTIMAL**

*Dimensi lebih panjang

**euro4
ready**

• Gambar pada brosur ini hanya ilustrasi, mungkin ada perbedaan dengan aktual kendaraan
• Mesin common rail pada Isuzu Giga sejak tahun 2011

REAL PARTNER. REAL JOURNEY.

SPESIFIKASI TEKNIS

SPESIFIKASI		NMR	NMR L	NMR HD 5.8	NMR HD 6.5
DIMENSI / DIMENSION					
Panjang / Overall Length [OAL]	mm	6,435	7,545	6,135	6,135
Lebar / Overall Width [OW]	mm	1,920	1,920	1,990	1,990
Tinggi / Overall Height [OH]	mm	2,345	2,345	2,345	2,345
Jarak Sumbu / Wheelbase [WB]	mm	3,360	4,175	3,360	3,360
Jalur Depan / Front Overhang [FOH]	mm	1,110	1,110	1,110	1,110
Jalur Belakang / Rear Overhang [ROH]	mm	1,965	2,260	1,665	1,665
Jarak Terendah ke Tanah / Min. Clearance [HH]	mm	220	220	200	200
Jejak Depan / Front Tread [AW]	mm	1,475	1,475	1,475	1,475
Jejak Belakang / Rear Tread [CW]	mm	1,425	1,425	1,495	1,495
Cabin to End [CE]	mm	4,830	5,930	4,530	4,530
MESIN / ENGINE					
Model		4HL1-TCS			
Tipe / Type		Direct Injection, Commonrail, SOHC, 4 Cylinder, VGS Turbo Intercooler			
Sistem Kontrol Emisi		EURO4 with EGR & DOC			
Diameter x Langkah / Bore x Stroke	mm	115 X 115			
Isi Silinder / Piston Displacement	cc	4,778			
Tenaga Maksimum / Max. Power	PS/ rpm	150 / 2,600			
Torsi Maksimum / Max. Torque	Kgm/rpm	41 / 1,400 - 2,600			
TRANSMISI / TRANSMISSION					
Model		MY6S	MY6S	MY6S	MY6S
Perbandingan Gigi / Gear Ratio					
	1st	5.979	5.979	5.979	5.979
	2nd	3.434	3.434	3.434	3.434
	3rd	1.862	1.862	1.862	1.862
	4th	1.297	1.297	1.297	1.297
	5th	1.000	1.000	1.000	1.000
	6th	0.759	0.759	0.759	0.759
	Rev	5.701	5.701	5.701	5.701
Perbandingan Gigi Terakhir / Final Gear Ratio		5.375	5.375	5.857	6.500

* Untuk meningkatkan mutu dan penyesuaian dengan perkembangan teknologi, spesifikasi dapat berubah sewaktu-waktu tanpa pemberitahuan.
** Ilustrasi merupakan contoh sebagian aplikasi di lapangan.

SPESIFIKASI		NMR	NMR L	NMR HD 5.8	NMR HD 6.5
BERAT / WEIGHT					
Berat Kosong Kendaraan / Curb Weight	kg	2,542	2,612	2,572	2,578
Berat Total Kendaraan / Gross Vehicle Weight [GVW]	kg	8,250	8,250	8,250	8,250
Kapasitas Gardan Depan / Capacity Front Axle	kg	2,710	2,450	2,710	2,710
Kapasitas Gardan Belakang / Capacity Rear Axle	kg	5,540	5,800	5,540	5,540
REM / BRAKE					
Tipe / Type		Hydraulic			
Rem Kaki / Service Brake		Hydraulic, saluran ganda dengan vacum booster			
Rem Tangan / Hand Brake		Expanding pada transmisi belakang			
Sistem Pengereman Gas Buang / Exhaust Brake		Exhaust brake, tuas berada di stir			
RODA / TYRE					
Ukuran Ban		7.50-16-14PR			
Ukuran Velg		16 X 6.00			
SUSPENSI / SUSPENSION					
Depan / Front		Semi elliptical laminated leaf spring dengan shock absorber			
Belakang / Rear		berdaya ganda			
LAIN-LAIN / OTHERS					
Kapasitas Tangki / Fuel Tank Capacity	ltr	100			
Radius Putar Minimum / Min. Turning Radius	m	7.3	8.5	7.1	
Daya Tanjak Maksimum / Max. Gradeability	%	39		44	50
Kecepatan Maksimum / Max. Speed	km/h	106		100	93
Aki / Accu	V-Ah	2 X 12 V - 65 Ah			
Alternator	V-A	24 - 60			
Kamera Mundur / Reverse Parking Camera		Ada			
Audio Head Unit		Ada			
USB Charging System		Ada			
APAR (Alat Pemadam Api Ringan)		Ada			
Fan Blower		Ada			
Garansi / Warranty		3 Tahun / 100,000 km			
Transmission PTO		Tidak Ada			Ada

DIMENSI

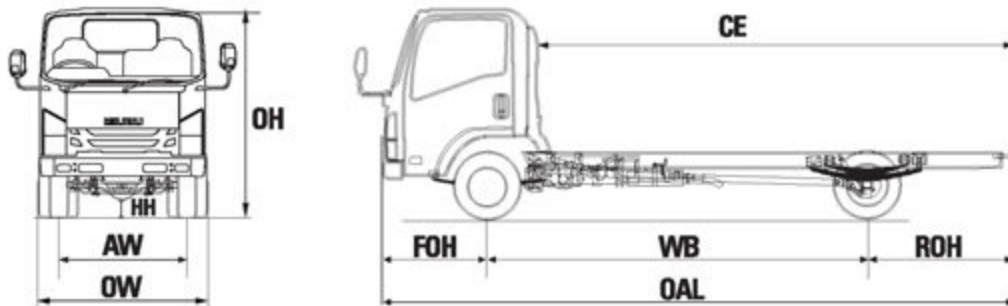

APLIKASI

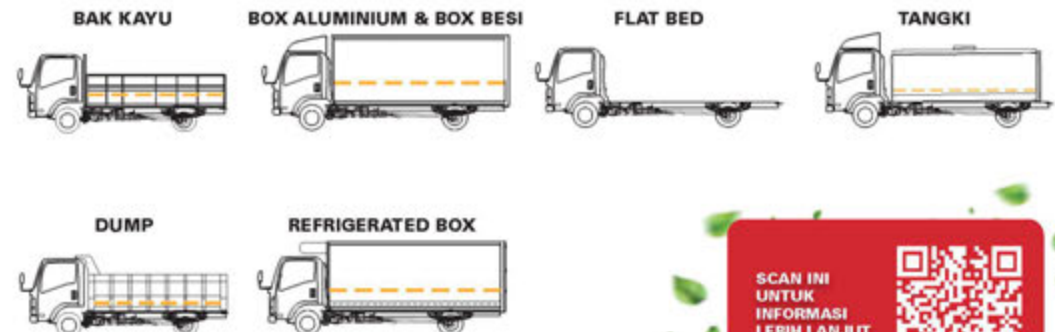

SCAN INI
UNTUK
INFORMASI
LEBIH LANJUT

